

## 180W 1 Gang LED Dimmer Switch (Rear Module)



### Product Description

It fits straight into your current wiring, though we do advise you to check the measurements before ordering to make sure it fits both your back box and dimmer switch.

The dimensions of this module are 53 x 28 x 42mm.

### Additional Information

**Intended Applications:** Indoor Use Only. Domestic lighting circuits.

**Safety Advice:** Not suitable for use with non-dimmable fluorescent bulbs and tubes, wire-wound or toroidal transformers, TRIAC dimmable loads or electric motors. Do not overload.

**Applicable Safety Standard:** BS EN 60669-2-1

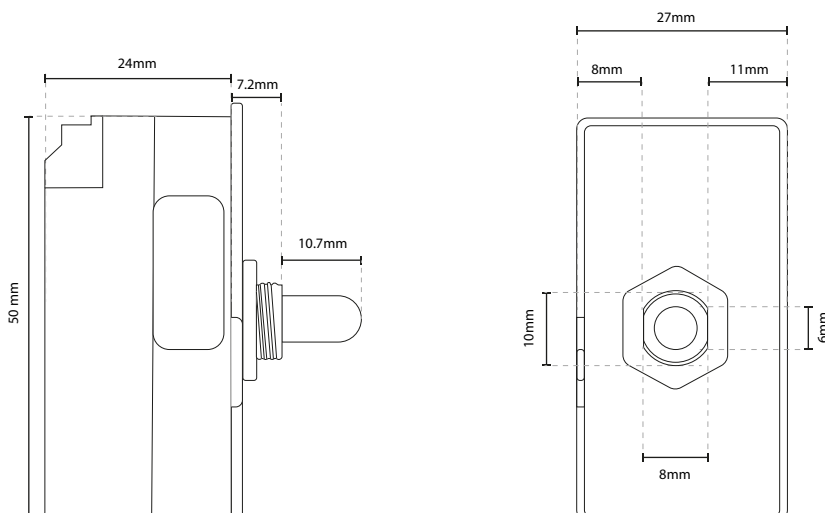

### Product Features

**Dimensions:** 53x28x42mm

**Operating Voltage:** 230v 50Hz

**Maximum Load Rating:** LED; 180W (Max. 20 LEDs)

**Minimum Load:** 10W

**Maximum Current Rating:** 0.78A

**Terminal (Live) Diameter:** 3.2mm; Capacity: 3 x 1.5mm<sup>2</sup>

**Warranty:** 1 Year

